

Application

Control valve with a tight shutoff of liquids, gases and steam in accordance with DIN or ANSI standards

Nominal sizes	DN 15 to 100 · NPS ½ to 4
Nominal pressure	PN 16 to 40 · Class 150 and 300
Ambient temperatures	-35 to 100 °C · -30 to 212 °F
Medium temperatures	-50 to 250 °C · -58 to 482 °F

The Type 3351 Pneumatic Control Valve consists of an on-off valve and a pneumatic actuator. Optionally, the valve can be equipped with a bellows seal or extension bonnet.

Valve body made of:

- Cast iron
- Spheroidal graphite iron
- Cast steel
- Cast stainless steel
- Valve plug with metal and soft sealing together
- Leakage rate Class VI in accordance with DIN EN 1349, Class VI in accordance with ANSI B16-104.

Attachment of solenoid valves and limit switches according to IEC 60534-6 and NAMUR recommendation. For details, see Information Sheet T 8350 EN.

Versions

Standard version for nominal pressures PN 10 to PN 40 or ANSI Class 150 and 300 with fail-safe action "valve CLOSED" or "valve OPEN"

- **Type 3351-1** (Fig. 1) · On-off valve with self-adjusting PTFE V-ring packing in nominal sizes DN 15 to DN 100 (NPS ½ to 4) for medium temperatures from -10 to 220 °C (14 to 428 °F)
- **Type 3351-1 · Version with bellows seal** (Fig. 2) · On-off valve with metal bellows and V-ring packing in nominal sizes DN 15 to DN 50 (NPS ½ to 2) for medium temperatures as listed in Table 1
- **Type 3351-1 · Version with extension bonnet** (Fig. 2) · On-off valve with extension bonnet, plug stem sealed with PTFE V-ring packing, nominal sizes DN 15 to DN 50 (NPS ½ to 2) for medium temperatures as listed in Table 1

Other versions

- With additional handwheel
- With reinforced spring
- For higher or lower medium temperatures
- For higher ambient temperatures



Fig. 1 · Type 3351-1 Pneumatic On-off Valve



Fig. 2 · Type 3351-1 Pneumatic On-off Valve, Version with bellows seal or extension bonnet

Principle of operation

Depending on the type of valve seat and the arrangement of the valve plug, the control valve features two different fail-safe actions which are used when the pressure acting on the diaphragm is reduced or when the control signal fails:

Fail Close action

The valve is closed upon supply air failure.

Fail Open action

The valve is opened upon supply air failure.

Direction of flow

The direction of the medium flow in the valve depends on the process medium and the selected fail-safe action.

For valves with Fail Close action for applications with gases and vapors, the direction of flow in the closing direction ($A \rightarrow B$) applies, except for the DN 100 version for which the direction of flow in the opening direction ($B \rightarrow A$) is prescribed.

For liquids, the medium **must** flow in the opening direction ($B \rightarrow A$).

For valves with Fail Open action, the medium flows in the opening direction ($A \rightarrow B$) regardless of the medium type.

Using the optional handwheel, valves with Fail Close action can be opened in case of a supply air failure, and valves with Fail Open action can be closed.

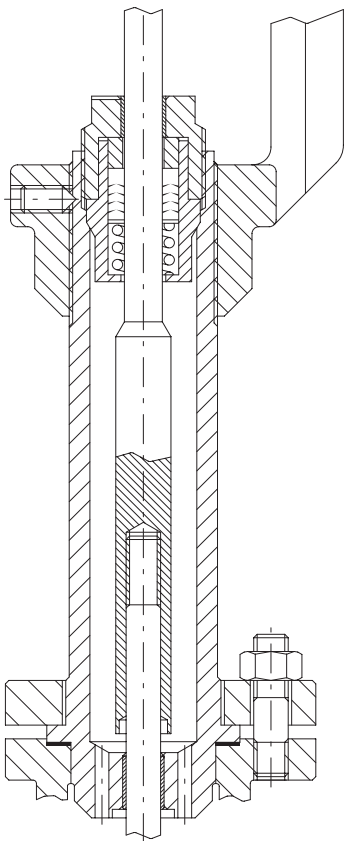

Fig. 3 · Detailed drawing of the extension bonnet

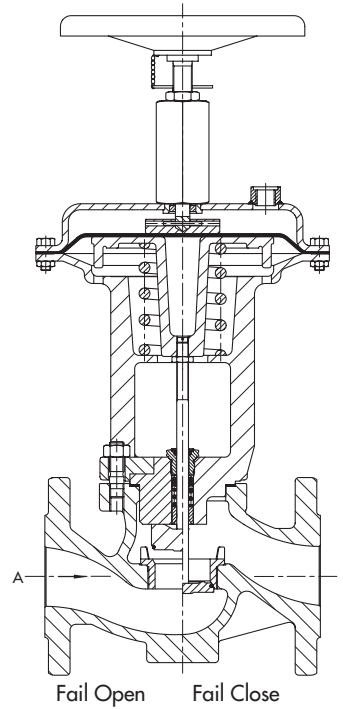

Fig. 4 · Type 3351-1 Pneumatic On-off Valve with handwheel

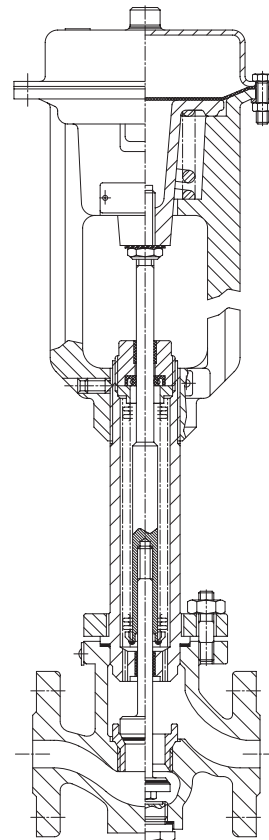

Fig. 5 · Type 3351-1 Pneumatic On-off Valve version with bellows seal

Table 1 · Technical data

Version	DIN				ANSI		
Body material	Cast iron EN-JL 1040	Spheroidal graphite iron EN-JS 1049	Cast steel 1.0619	Stainless cast steel 1.4581	Carbon steel A 216 WCC	Stainless cast steel A 351 CF8M	
Nominal pressure	PN 10, 16	PN 10, 16, 25	PN 10, 16, 25, 40		Class 150 and 300		
Nominal size	Standard	DN 15 to 100				NPS ½ to 4	
	Bellows seal/ extension bonnet	DN 15 to 50				NPS ½ to 2	
Connecting flanges	Form B acc. to DIN EN 1092-1		Form B1 acc. to DIN EN 1092-1		RF		
Temperature ranges in °C (°F) · Permissible operating pressures acc. to the pressure-temperature diagrams (see Information Sheet T 8000-2 EN)							
Ambient temperature	-35 to 100 °C (-30 to 212 °F)				-35 to 100 °C (-30 to 212 °F)		
Medium temperature	-10 to 220 °C (14 to 428 °F)				-10 to 220 °C (14 to 428 °F)		
High-temperature version	-10 to 250 °C (14 to 482 °F) ¹⁾				-10 to 250 °C (14 to 482 °F) ^{1) 4)}		
Low-temperature version	-		-50 to 220 °C (-58 to 428 °F)		-29 to 220 °C (-20 to 428 °F) ⁴⁾	-50 to 220 °C (-58 to 428 °F) ^{3) 4)}	
Leakage class	Class VI (DIN EN 1349)				Class VI (ANSI B16-104)		

1) With soft-seated special plug and bellows seal or extension bonnet

2) Up to max. 50 % of the nominal pressure and with bellows seal or extension bonnet

3) Additional impact test certification required between -29 °C (-20 °F) and -50 °C (-58 °F)

4) With bellows seal or extension bonnet only

Table 2 · Materials

Valve	DIN				ANSI	
Body	Cast iron EN-JL 1040	Spheroidal graphite iron EN-JS 1049	Cast steel 1.0619	Stainless cast steel 1.4581	Carbon steel A 216 WCC	Stainless cast steel A 351 CF8M
Seat	1.4006			1.4404/1.4571	A182 F6a CL2	316Ti/316L
Plug	1.4404/1.4571 · Seat ring made of reinforced PTFE					
Body gasket	Graphite on metal core					
Actuator diaphragm	NBR (nitrile rubber) with fabric reinforcement · Materials for higher ambient temperatures on request					
Standard version						
Valve bonnet	Spheroidal graphite iron EN-JS 1049	Spheroidal graphite iron EN-JS 1049	Cast steel 1.0619	Valve bonnet 1.4571/1.4404 welded to bonnet 1.0619	Cast steel A 216 WCC	Valve bonnet 316L, welded to bonnet A 216 WCC
Guide bushing	1.4104			1.4404	1.4104	316L
Packing	V-ring packing PTFE with carbon · Spring 1.4310					
Threaded bushing assembly	1.4404 + carbon				316L + carbon	
Version with bellows seal or extension bonnet						
Bellows seal or extension bonnet	1.0460			1.4404	A105	316L
Actuator flange	Cast iron EN-JL 1040	Cast steel 1.0619			Cast steel A 216 WCC	
Guide bushing	Fiber-reinforced plastic					
Sealing	Bellows seal: Bellows 1.4571 and PTFE/graphite V-ring packing · Spring 1.4310					
	Extension bonnet: PTFE/graphite V-ring packing · Spring 1.4310					
Guide nut	1.4404 and fiber-reinforced plastic				316L and fiber-reinforced plastic	
Flange of bellows seal or extension bonnet	1.0460			1.4301	A105	304

Table 3 · Control pressure and maximum differential pressure · All pressures in bar and psi

Nominal size (bellows seal or extension bonnet up to DN 50/2")	DN	15	20	25	32	40	50	65	80	100	
	NPS	½	¾	1	–	1½	2	2½	3	4	
Flow rate	Kvs	6.3	10	14	25	31	40	72	90	170	
	Cv	7.5	12	16	–	36	47	84	105	200	
Pneumatic actuator	Effective area in cm ²	60			186			255		700	
	Travel in mm	8			10			12.5		30	
Max. supply pressure		6 bar/88 psi									
Standard version											
Fail Close											
Min. control pressure to open the valve at Δp_{max}		4 bar/58 psi									
Max. perm. diff. pressure Δp_{max}	Vapor, gas A → B	20 bar/290 psi			16 bar/235 psi			10 bar/145 psi		–	
	Liquids B → A	16 bar/235 psi			10 bar/145 psi			5 bar/73 psi		10 bar ¹⁾ 145 psi	
Fail Open											
Min. control pressure to close the valve at Δp_{max}		4.5 bar/65 psi								4 bar/ 58 psi	
Max. perm. differential pressure Δp_{max} with vapors, gases, liquids		20 bar/290 psi			16 bar/235 psi			10 bar/145 psi			
Special version for Fail Close											
Min. control pressure to open the valve at Δp_{max}		5.5 bar/80 psi								–	
Max. perm. differential pressure Δp_{max} with vapors, gases, liquids ²⁾		30 bar/435 psi			20 bar/290 psi			7 bar/102 psi		–	

1) Also applies to vapors and gas

2) For direction of flow B → A (see Fig. 4)

Table 4 · Dimensions for Type 3351

Valve	DN	15	20	25	32	40	50	65	80	100	
	NPS	½	¾	1	–	1½	2	2½	3	4	
Length L	PN 10/40	mm	130	150	160	180	200	230	290	310	350
	Class 150	in	7.25			–	8.75	10	10.88	11.75	13.86
		mm	184			–	222	254	276	298	352
	Class 300	in	7.50	7.63	7.75	–	9.25	10.50	11.50	12.50	14.49
in		191	194	197	–	235	267	292	318	368	
Diaphragm diameter	mm	150			240			280		390	
Loading pressure connection	a	G ¼			G ¼			G ⅜			
Standard version											
H1	mm	275			300			350		485	
H2	mm	45			72			98		118	
H3 ¹⁾	mm	380			380			415		565	
Version with bellows seal or extension bonnet											
H4	mm	415			430			–			
H2	mm	55			80						
H3 ¹⁾	mm	520			535						

1) Minimum clearance for removing the actuator; version with handwheel: add 150 mm for DN 80 or smaller; add 210 mm for DN 100

Table 5 · Weights for Type 3351

Standard version	DN	15	20	25	32	40	50	65	80	100
	NPS	½	¾	1	–	1½	2	2½	3	4
Weight, approx. kg	PN 10/40	11	12	12	25	26	29	48	52	70
	Class 150	11	12	13	–	23	27	47	52	64
	Class 300	12	13	14	–	25	29	50	52	64
Version with bellows seal or extension bonnet										

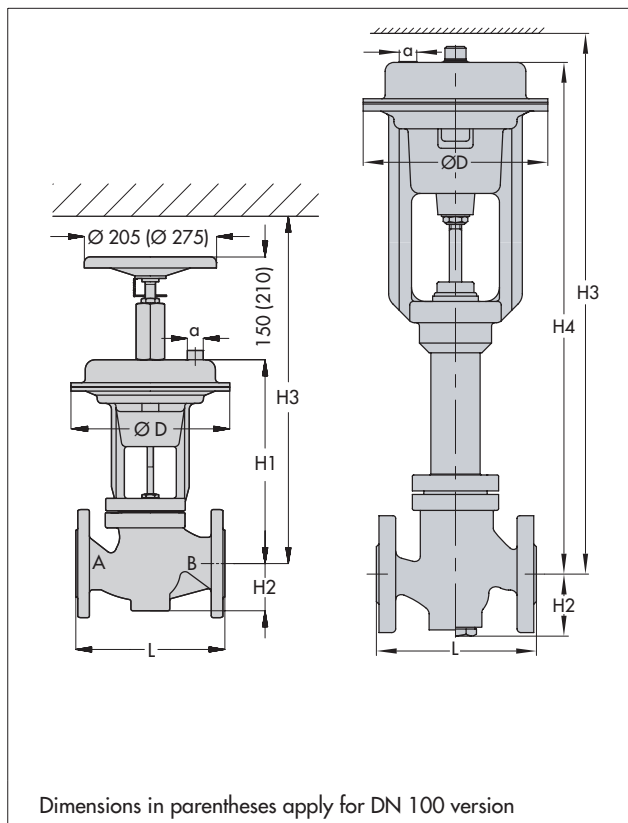

Ordering text

- Type 3351 Pneumatic On-off Valve
- Nominal size DN/NPS
- Nominal pressure PN/Class
- Body material According to Table 1
- Fail-safe action Fail Close or Fail Open
- Control pressure ... bar
- Handwheel Without / with
- Special versions Bellows seal/extension bonnet
Version for high or low temperatures
- Accessories Solenoid valve and/or
electric or pneumatic limit switch

Specifications subject to change without notice.



SAMSON AG · MESS- UND REGELTECHNIK
Weismüllerstraße 3 · 60314 Frankfurt am Main · Germany
Phone: +49 69 4009-0 · Fax: +49 69 4009-1507
Internet: <http://www.samson.de>

T 8039 EN

2008-09